

ANTHONY
LIFTGATES, INC.®

MTU-GLR



*Shown with optional features.

MAGNUM TUCKUNDER™

LIFTING CAPACITIES (LBS):
2500, 3000, 4000, 5000, 6000

KEY ADVANTAGES

- **GLR - Gentle Level Ride**
Smooth, level up-down operation. Platform tilts gently at ground and re-levels before lifting cycle begins.
- **Twin Cylinder Drive**
Powerful lift with low pressure helps to extend hydraulic component life.
- **Wedge Platform**
Wedge design provides easy, secure loading.
- **Power Down**
Reliable cycle time in all weather conditions.
- **Lifetime Warrantied Service Free Bushings**
Used at all critical pivot points to reduce wear without the need for routine lubrication.

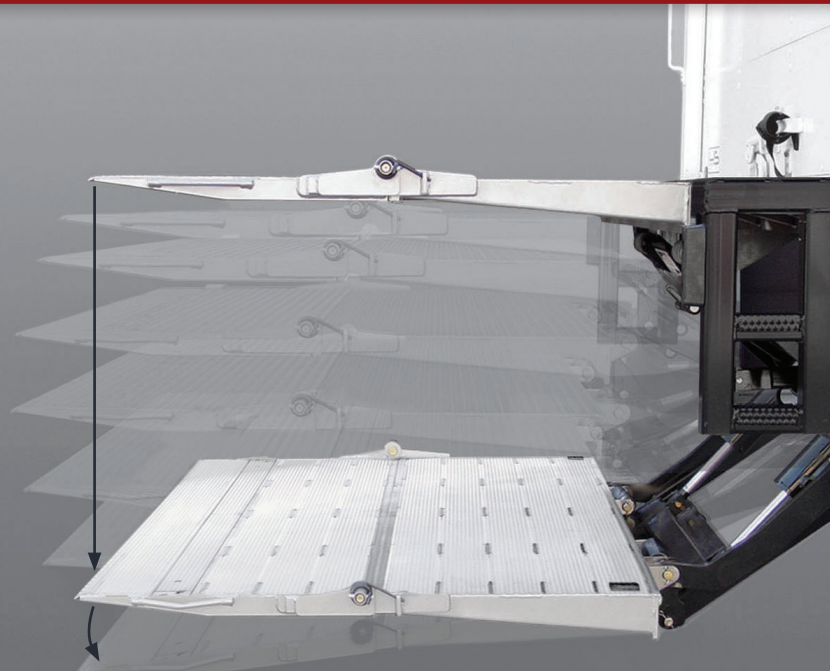

QUALITY, RELIABILITY, CUSTOMER SERVICE

MADE IN THE USA 

STANDARD FEATURES

- **Spring Assist Platform**
Dual torsion springs provide effortless platform operation.
- **Ground Contact Rollers**
Rollers prevent scraping damage to liftgate and concrete or asphalt.
- **HD Mechanical Safety Latch**
Redundant-system stowage in addition to hydraulic lock.
- **Max Duty Dock Bumpers**
Helps protect floor extension from contact with dock. Includes rubber bumpers.
- **EZ Mount**
Ships factory assembled, filled, and tested with notched center mark for easy installation. Floor extension may be bolted to the truck.
- **Circuit Protection**
200 Amp fuse protects truck wiring from a "dead short".
- **CHS - Centralized Hydraulic System**
All sensitive hydraulic and electrical components housed safely within the stainless steel pump box.
- **Marine Duty Potted Toggle Switch**
Heavy duty toggle, potted to permanently separate and seal electrical connections from corrosion.
- **3/16" Steel Floor Extension**
Rugged and attractive surface.
- **Industry-Leading Warranty**
3 years mechanical + 3 years electrical & hydraulic, parts and labor.
- **Pressure Compensated Flow Valve**
Constant, controlled speeds at all times. Prevents "free-fall" under certain hydraulic failures.
- **Cab Cutoff Switch**
Prevents unauthorized liftgate operation.
- **Anthony 3-Step Powder Coat**
Steel components are washed, shot blast prepped, and coated with premium finish.

QUALITY COMES STANDARD

AVAILABLE MODELS, PLATFORMS AND CAPACITIES

Model	Capacity (lbs)	Bed Height Range
MTU-GLR-25	2500	47" - 57"
MTU-GLR-3	3000	47" - 57"
MTU-GLR-4	4000	47" - 57"
MTU-GLR-5	5000	47" - 57"
MTU-GLR-6	6000	47" - 57"
Available Platforms		
Steel Main/Aluminum Flip 80" x 60" Wedge		
All Aluminum 80" x 60" Wedge*		

*Not available on MTU-GLR-6.

OPTIONS

- Alternate floor extensions: 3/16", 1/4", or 3/8" steel. 96" or 102" Wide.
- Wireless, removable handheld corded, flush mount, or dual control options.
- Stainless steel toggle switch guard
- Stainless steel battery box
- Trail Charger, solar charging
- Third step add-on for dock bumper
- Galvanized finish with extended warranty
- ICC bumper - trailer certified
- Ignition cut-off switch
- Trailer sub-frame mounting kit
- Dual, foot-operated cart stops

TRUCK MOUNTING REQUIREMENTS

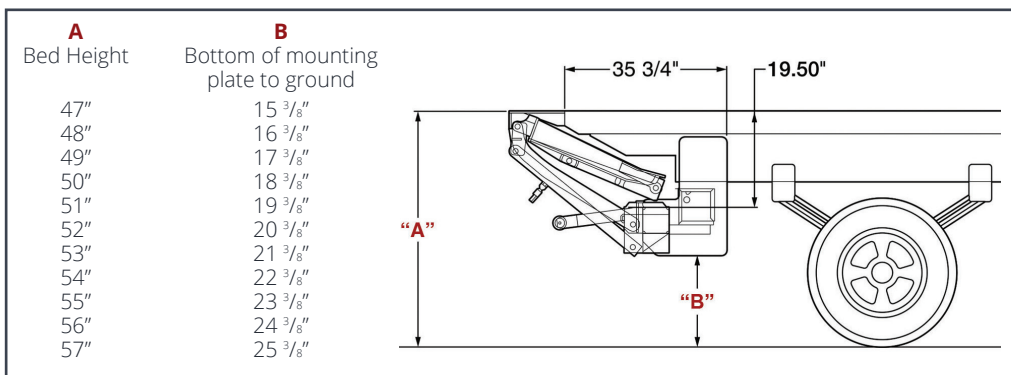

Bill's Auto & Truck Repair
complete mechanical service

Bill's Auto & Truck Repair
sales@billsautoandtruckrepair.com
www.billsautoandtruckrepair.com
1216 Rand Road
Des Plaines, IL 60016
Phone: (847) 296-3166